



**Putzmeister**

# Transit Mixers

P7+ | P7+ PT0 | P8 PT0 | P9 PT0 | P10 PT0



**23% bigger feeder hopper for fast and spillage free concrete loading**

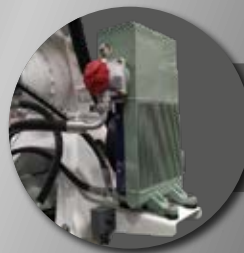

**Highest in class, 18-litre hydraulic oil cooler system for optimal performance**



**32% bigger discharge chute for faster concrete discharge**



**72 CC / 90 CC hydraulic motor provides higher torque for tough concrete mixes**



**Box frame with a yield strength of 530 N/mm<sup>2</sup>, highest in its segment**

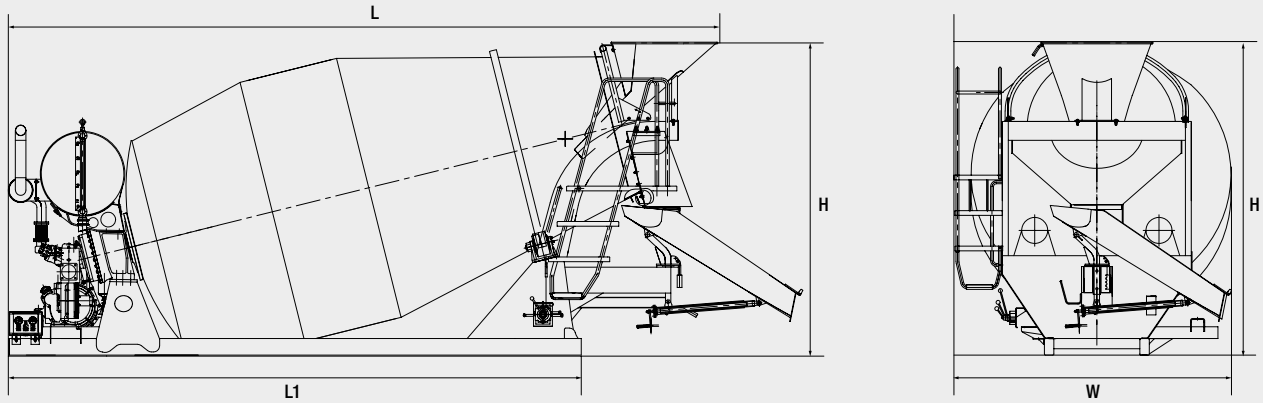

Parameters	Units	P7+	P7+ PTO	P8 PTO	P9 PTO	P10 PTO
Nominal Filling Capacity	L (m <sup>3</sup> )	7000 (7)	7000 (7)	8000 (8)	9000 (9)	10000 (10)
Waterline Volume	L	8260	7960	8970	10280	11600
Geometric Volume	L	12730	12710	14250	15850	17500
Filling Ratio	%	64.8	55.1	56.1	56.8	57.1
Drum Speed	rpm	0-14	0-14	0-14	0-14	0-14
Max Drum Diameter	mm	2260	2260	2260	2260	2260
Installation Angle	Deg	14	14	13	13	12
Water Tank Capacity	L	450	500	500	500	500/600
Drive Unit	Type	Slave Engine	EPTO	EPTO	EPTO	EPTO
Rotational Direction (Loading)		Anti-Clockwise	Anti-Clockwise	Anti-Clockwise	Anti-Clockwise	Anti-Clockwise
Rotational Direction (Discharging)		Clockwise	Clockwise	Clockwise	Clockwise	Clockwise
Length - L	mm	6385	6385	6735	7085	7435
Length - L1	mm	5050	5050	5400	5750	6100
Height - H	mm	2670	2670	2730	2785	2785
Width - W	mm	2390	2390	2390	2390	2390
Weight	kg	3750	3400	4200	4650	4950

### Putzmeister Concrete Machines Pvt. Ltd.

Plot No. N4, Phase 4, Verna Industrial Estate,  
Salcette - Goa 403 722. INDIA

Tel.: +91 (832) 6696 000 · Fax: +91 (832) 6696 300

Whatsapp: +91 91585 34123 · [www.putzmeister.com](http://www.putzmeister.com)



For all your support needs, [contact.india@putzmeister.com](mailto:contact.india@putzmeister.com)

Regional Offices: NORTH: 011 4200 5600, EAST: 033 6614 2525, WEST: 022 2636 0181 / 82, SOUTH: 040 4010 1015

Service Call Centre: NORTH: 99100 25721, EAST: 84200 59909, WEST: 90821 04420,

SOUTH (AP, TN): 78939 22727, SOUTH (KA, KL): 90080 65829