

Trans MixTML 3230

Mixing capacity up to 10 m³ /h

Delivery pressure up to 40 bar

Trans Mix
Superior logistics systems

Note: Standard version with 3 axes. Dimensions and weight depending on vehicle, pump, and equipment
Dimensions in mm, illustration contains optional equipment

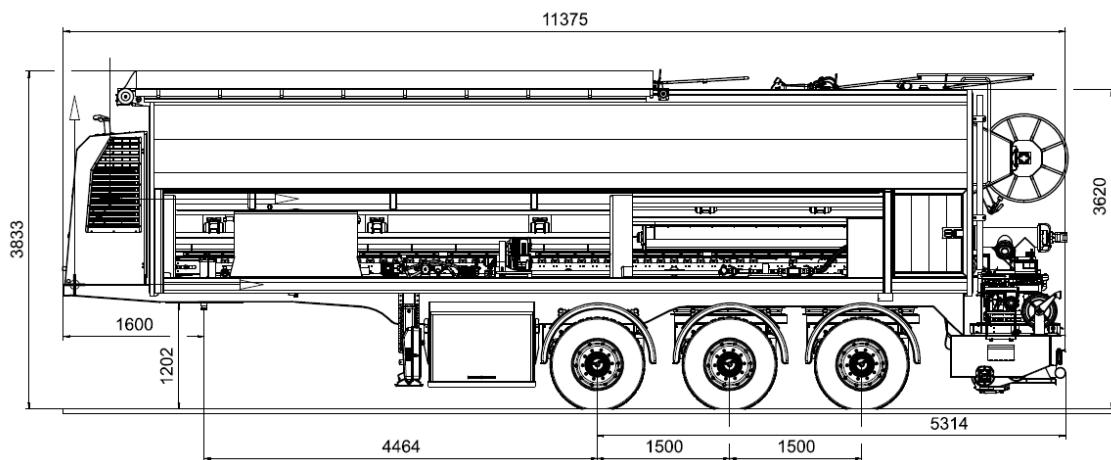

Specifications

(*applicable depending on the country of registration, **depending on equipment, °lower edge screen grille)

Semitrailer		
Length	m	11,4
Width	m	2,5
Height	m	3,9
Chamber volume	m ³	30
Loading height	m	3,7
Loading length	m	5
Weight	t	39*
Fifth wheel load	t	12
Axle load	t	9
Net weight	t	12,6 **

Motor		
Kubota		V3307
Emission		Stage V
Power	kW	55,4
Diesel fuel		EN590
Tank volume	L	140
Pump / Mixer / Hopper		
Worm pump		7515
		2L8
Delivery line	∅	DN 50
	bar	40
Mixer	L	475
Hopper°	L	500

Scope of delivery series:

- 3-axle semi-trailer with 30 m³ aluminium body
- Sides under trough closed with tarpaulin
- Axle 2 and 3 with forced steering
- Connection filling water tank with filter
- Ascent, railing and catwalk on trough
- Control station stainless steel with LED lighting
- Dunlop or Goodyear tyres on steel rim
- Binder dosing with residual emptying
- Binder chamber with 2 dome closures, incl. preparation of pneumatic injection
- Tool kit with standard accessories
- COC paper for approval
- Display with rubber keyboard
- Radio system without repeater
- Keypad with optical user guidance
- Terminal box stainless steel
- LED headlights 4-fold
- LED tail lights and rear headlights
- Air suspension trailer, 1st axle with lift (traction aid)
- Mobile control with 16 recipes
- Vibrator for aggregate and binder electric, 2-fold each
- Electric sliding roof with radio control
- Hose reel conveyor hose for 100 m DN 50 mortar hose with drive
- Hose reel water hose incl. 50 m 1 inch hose extendable
- Storage box under chassis, continuous (left/right side) with lashing rails
- Landing gears front side mechanically 12 t each
- Step at the rear
- Underrun protection according to ECE R58.3
- Water purification set with hose and spray nozzle
- Water tank 1100L in sides trough slope
- Central lubrication system for mixing technology and trailer
- Aggregate dosing with conveyor belt
- Aggregate chamber with traction aid

Options:

- Level probe binder chamber
- Display speed feed pump
- Automatic adjustment of water addition to residual moisture aggregate
- Document printer for customer and own document (incl. recipe)
- Tyres Premium Conti / Michelin on alloy rim
- Labeling tarpaulin custom built
- Labeling side wall trough custom built
- Binder chamber 2-piece
- Data logger mixture list
- Fire extinguisher 6 kg
- Conveyor hose DN 50 in different lengths
- Radio system with repeater
- Generator 8,5 kVA 400V 3p 16A, 230V 1p
- Pouring hose 20 m DN40
- Heating water tank 400 V 2x3kW
- High-pressure cleaner 18 L 180 bar
- Hose reel HP hose (cleaner)
- LED signal lights 8-fold
- Air compressor
- Overground blowing with max. probe, signal horn and filter
- Pump system 7515 premium
- Wireless rear view camera
- Vibrator binder chamber 4-fold
- Vibrator surcharge chamber 4 or 6-fold
- Vibro Aerators binder chamber
- Telematics system for remote enquiry, working and travel time, recipe, mixtures, and localization
- Control panel chassis TIS
- Additive dosage unit 1 to 3-fold