



Putzmeister

Transit Mixers

P7+ | P8 PT0 | P9 PT0 | P10 PT0



23% bigger feeder hopper for fast and spillage free concrete loading



Highest in class, 18-litre hydraulic oil cooler system for optimal performance



32% bigger discharge chute for faster concrete discharge



72 CC / 90 CC hydraulic motor provides higher torque for tough concrete mixes



Box frame with a yield strength of 530 N/mm², highest in its segment

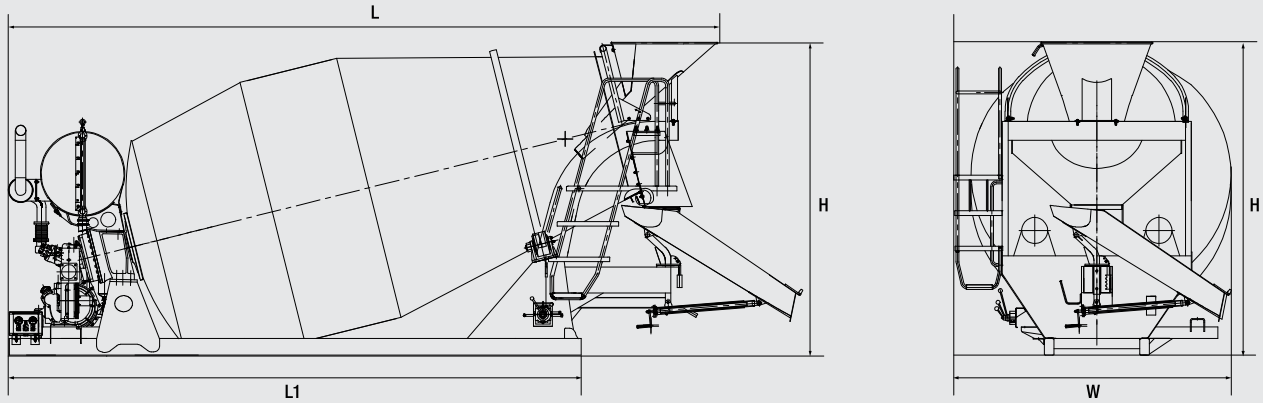

Parameters	Units	P7+	P8 PTO	P9 PTO	P10 PTO
Nominal Filling Capacity	L (m ³)	7000 (7)	8000 (8)	9000 (9)	10000 (10)
Waterline Volume	L	8260	8970	10280	10800
Geometric Volume	L	12730	14250	15850	17500
Filling Ratio	%	55.1	56.1	56.8	57.1
Drum Speed	rpm	0-14	0-14	0-14	0-14
Max Drum Diameter	mm	2260	2260	2260	2260
Installation Angle	Deg	14	13	13	12
Water Tank Capacity	L	450	500	500	500/600
Drive Unit	Type	Slave Engine	EPTO	EPTO	EPTO
Rotational Direction (Loading)		Anti-Clockwise	Anti-Clockwise	Anti-Clockwise	Anti-Clockwise
Rotational Direction (Discharging)		Clockwise	Clockwise	Clockwise	Clockwise
Length - L	mm	6385	6735	7085	7435
Length - L1	mm	5050	5400	5750	6100
Height - H	mm	2670	2730	2785	2785
Width - W	mm	2390	2390	2390	2390
Weight (Mixer Standard)	kg	3750	4200	4650	4950
Weight (Concrete)	kg	16800	19200	21600	24000

Putzmeister Concrete Machines Pvt. Ltd.

Plot No. N4, Phase 4, Verna Industrial Estate,
Salcette - Goa 403 722. INDIA

Tel.: +91 (832) 6696 000 · Fax: +91 (832) 6696 300

Whatsapp: +91 91585 34123 · www.putzmeister.com



For all your support needs, contact.india@putzmeister.com

1800 - 267 - 2678

TOLL-FREE NUMBER FOR ENQUIRIES AND SERVICE REQUESTS